

MATERIAL

Cast aluminium with epoxy resin coating, matte finish.

HUB CAP

Technopolymer, light grey colour, glossy finish.

STANDARD EXECUTIONS

Polyamide based (PA) technopolymer fold-away handle, black colour, matte finish.

AISI 303 stainless steel pin, AISI 316 sintered stainless steel base, AISI 303 stainless steel screw.

- **GN 472.5-B:** H7 reamed hole.
- **GN 472.5-V:** H11 square hole.

Colour index:

- **SW:** RAL 9005 black colour.
- **SR:** RAL 9006 grey colour.

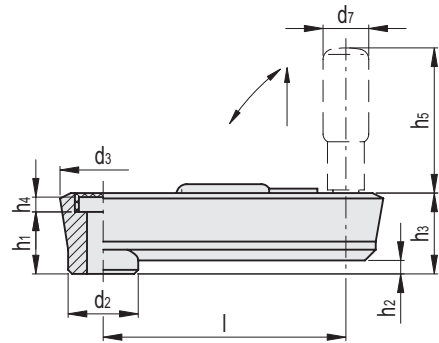
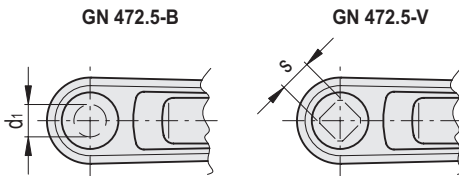

Conversion Table	
1 mm = 0.039 inch	
mm	inch
80	3.15
100	3.94
125	4.92

GN 472.5-B

Code	Description	l	d1 H7	d2	d3	h1	h2	h3	h4	h5	d7	⚖
GN.22753	GN 472.5-80-B10-SW	80	10	23	30	19.5	4	25.5	4.3	43	16	145
GN.22751	GN 472.5-80-B10-SR	80	10	23	30	19.5	4	25.5	4.3	43	16	145
GN.22763	GN 472.5-100-B12-SW	100	12	26.7	35	23.5	5.5	29.5	4.2	57.5	18	213
GN.22761	GN 472.5-100-B12-SR	100	12	26.7	35	23.5	5.5	29.5	4.2	57.5	18	213
GN.22773	GN 472.5-125-B14-SW	125	14	28	37	30.5	10.5	36.5	4.2	76.5	24	305
GN.22771	GN 472.5-125-B14-SR	125	14	28	37	30.5	10.5	36.5	4.2	76.5	24	305

GN 472.5-V

Code	Description	l	sH11	d2	d3	h1	h2	h3	h4	h5	d7	⚖
GN.22755	GN 472.5-80-V10-SW	80	10	23	30	19.5	4	25.5	4.3	43	16	142
GN.22757	GN 472.5-80-V10-SR	80	10	23	30	19.5	4	25.5	4.3	43	16	142
GN.22767	GN 472.5-100-V12-SW	100	12	26.7	35	23.5	5.5	29.5	4.2	57.5	18	210
GN.22765	GN 472.5-100-V12-SR	100	12	26.7	35	23.5	5.5	29.5	4.2	57.5	18	210
GN.22777	GN 472.5-125-V14-SW	125	14	28	37	30.5	10.5	36.5	4.2	76.5	24	301
GN.22775	GN 472.5-125-V14-SR	125	14	28	37	30.5	10.5	36.5	4.2	76.5	24	301

